

# AUTOCLEAR® 150150 & 150180

## 1.5m x 1.5m & 1.5 m x 1.8 m Cargo Scanner For Explosives, Weapons, Contraband & Manifest Fraud

Features brushed stainless covering and motor rollerbeltless conveyor

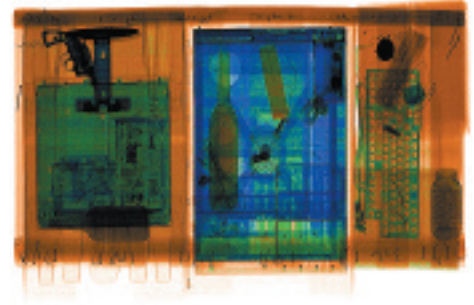

RealClear® reveals narcotics in a bottle and bomb components in real time, without lags and delays. autoScale® displays contents at Pentium 4 resolution automatically and without distortion.



Available operator table and dual or LCD monitors (one 17" CRT is the normal configuration).

Control Screening is the leading worldwide producer of fast, reliable and sophisticated X-ray, Metal and Trace Detection screening systems. Visit us at [www.controlscreening.com](http://www.controlscreening.com). Ask about our mobile and other systems. Our advanced systems and options are often integrated, leased or rented.

The AUTOCLEAR® 150150 (featuring a 1.5 m wide x 1.5 m high or 59" wide x 59" high tunnel opening), and 150180, it's 1.8 m high version, are heavy-duty, conveyORIZED, X-ray scanners designed for screening cargo and large checked luggage, detecting concealed weapons, explosives, narcotics, currency, contraband or manifest fraud at:

**Airports • Seaports  
Customs • Corporate Facilities  
Government Facilities  
Checkpoints • Loading Docks  
Mailrooms • Cruise  
Warehouses • Nuclear  
Access Control • Special Events  
Rail or Bus Stations  
Borders • Military Sites**

### Features

- ➔ Low to the floor, very heavy-duty, high capacity motor roller conveyor with easy changeouts. Extremely rugged frame construction uses less floor space and head room.
- ➔ Parcel contents are displayed at normal scale, wherever located, automatically and without distortion (autoScale®). RealClear® function reveals components of dense items in realtime without lags or delays.
- ➔ Features Pentium 4, 17" monitor, Multi-Energy Color with Organic/Inorganic Stripping, RealClear®, autoScale®, autoDensAlert®, autoOutline®, autoSensing®, autoCal®, Lighten, Help, DensityScan, and Low Density Stripping, among other features.
- ➔ TIP, Training and Image Archiving also available. autoMatalert®, option highlights suspect materials using atomic number and density.
- ➔ autoSensing® eliminates the need for troublesome photosensors or footpad switch. Assures 100% screening of thin blades or plastique in courier envelopes or magazines, or of bag already in tunnel at start-up.
- ➔ Interactive training and highly responsive local service. Engineered, made and rigorously tested in the USA to ISO 9001 and regulatory standards.

Leading contraband threat detection & field support, since 1937

# AUTOCLEAR®

[autoclearus.com](http://autoclearus.com)

Scintrex® • CheckGate® • Dynavision® • Control Screening® • Federal Labs®  
U.S. Canada Europe Dubai Latin America Beijing Hong Kong Singapore

# Model 150150 & 150180 X-ray Specifications

## Overall Dimensions:

723.9 cm (285") L x 276.9 cm (109") W x 203.2 cm (80") H  
(150180 is 30 cm higher).

## Inspection Capabilities

Tunnel Size: 59" wide (150 cm), 59" high (150 cm). 150180: 79" or 180 cm high.  
Material Penetration: 27-29 mm steel  
Contrast Sensitivity: Over 2 million color tones.  
Resolution: 38-40 AWG wire  
Conveyor: Height: 27 cm or approx. 10.5" off floor.  
Speed: Variable, up to 3 m per second. Reversible.  
Pulling Weight: Approx. 1,200 kg (2,700 lbs) (Higher pulling weights available).  
autoTracking®: Optional belt conveyor guaranteed to autoTrack for life, with toggles.  
Film Safety: Guaranteed for high-speed films up to ISO 1600 (33 DIN).  
**\*Full autoSensing® without photosensors, moving parts, or footpad.** **Reduces downtime and assures all magazines, envelopes or items are scanned, no matter how thin, or of bag already in tunnel at start-up. Enhances radiation safety.**

## X-ray Generator

X-ray tube head: Self-contained, shielded tank  
High voltage rating: 160 kV, 140 kV Operating Voltage (Optional higher kV units available, up to 450 kV).  
Duty cycle: 100% with sealed oil bath cooling.  
Beam orientation: Diagonal from side.  
Dose rate per exam: 0.1 mR. Lower doses available.

## X-ray Detectors

Surface-mounted, multilayer, fully integrated, high frequency, solid state detectors using high-speed processors and advanced Pentium 4 signal processing with Multi-Energy.

## Video

Standard with color 17" SVGA monitor. High resolution, flicker-free, .21 dot pitch, low rad. monitor, 1280 x 1024 video card. Multi-Energy color included with available second monitor or flat screen or larger monitor(s). Displays organics in orange and inorganics in blue, both overlapping in green and very dense objects in black.

## Standard Features

- Multi-Energy organic and inorganic color & stripping
- RealClear®
- autoDensAlert®
- autoTracking®
- autoSensing®
- autoOutline®
- autoScale®
- autoCal®
- Dark & Light enhance
- DensityScan
- Color; Reverse B/W
- High/Low Density & Stripping
- High density
- Help
- Fast (25 second) initial warm-up
- Fully functional, robust, low profile
- Reversible conveyor direction

## Options

- autoMatalert®
- Threat Image Projection (TIP)
- Roller bed or conveyor extensions
- Tropical Humidity Kit
- Image Archiving
- Power conditioner, or UPS
- CE mark
- Extra pulling power
- 63mm at 300+ kV penetration
- 115mm at 450 kV penetration
- Locking metal keypad cover
- kV, mA meter or item counter
- LCD, dual or larger monitor(s)
- Footpad or optical on/off
- Variable height keypad mount
- Table or locking monitor hood
- Remote operation; printer or VCR cable
- Built-in training
- Rentals or leases
- autoNet
- TipNet

## Physical Details

Dimensions: See drawing  
Weight/150150: 3,100 lbs (1,406 kg) / 3,600 lbs (1,633 kg) crated  
Weight/150180: 3,450 lbs (1,565 kg) / 3,950 lbs (1,792 kg) crated  
Construction: Detachable electronics and generator module. Brushed stainless steel framed with steel, composites, and a corrosion-resistant command center.  
Environmental Conditions: Temperature range: 32° - 104° F, 0° - 40° C • Humidity 20% - 95%, non-condensing.  
Electrical Power Requirements: Consumption: <2.5 KVA, 3 phase 208, 380, 415, or 480 volts AC ± 10%, All at 50 or 60 Hz (single phase optional)

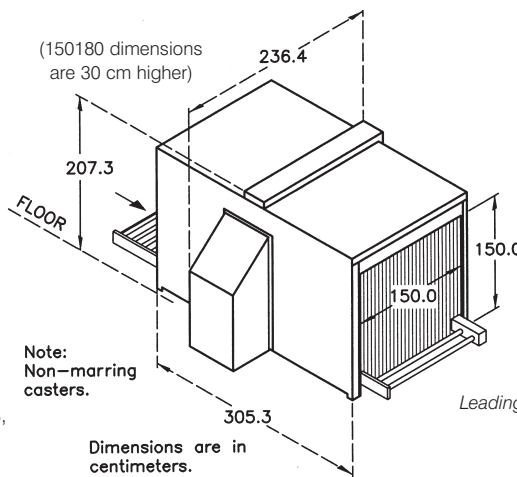

[www.autoclearus.com](http://www.autoclearus.com)

## Technology Labs & Headquarters Plant

2 Gardner Road  
Fairfield, NJ 07004-2206 USA  
Tel: 1 (973) 276-6161  
Fax: 1 (973) 276-6162  
[info@autoclearus.com](mailto:info@autoclearus.com)

## Central EU

[eu@autoclearus.com](mailto:eu@autoclearus.com)  
Tel: + 33 2 38 61 97 00  
Fax: + 33 2 38 61 97 01

## Southern EU

[seu@autoclearus.com](mailto:seu@autoclearus.com)

## Northern EU

[neu@autoclearus.com](mailto:neu@autoclearus.com)

## Canada & Scintrex

[info@scintrextrace.com](mailto:info@scintrextrace.com)  
300 Parkdale Ave., Ottawa  
Ontario, Canada K1Y 1G2  
Tel: 1 (613) 224-1061  
Fax: 1 (613) 224-2603

## Asia Southeast & North

[sasia@autoclearus.com](mailto:sasia@autoclearus.com)  
[nasia@autoclearus.com](mailto:nasia@autoclearus.com)  
[china@autoclearus.com](mailto:china@autoclearus.com)

## Latin America

[latina@autoclearus.com](mailto:latina@autoclearus.com)

## Middle East

[ME@autoclearus.com](mailto:ME@autoclearus.com)  
Dubai, UAE  
Tel: + 971 6 557 4505  
Fax: + 971 6 557 4507

## Western U.S.

[sw@autoclearus.com](mailto:sw@autoclearus.com)

## TRANSACTOR SP. Z O.O.

Ul.Sapieżyńska 10  
00-215 Warszawa  
Tel. 022 635 59 02  
Fax 022 635 62 44

### Email:

[security@transactor.pl](mailto:security@transactor.pl)  
[export-import@zigzag.pl](mailto:export-import@zigzag.pl)

ISO 9001-2000 Certified

[www.autoclearus.com](http://www.autoclearus.com)

[www.scintrextrace.com](http://www.scintrextrace.com) [www.fed-labs.com](http://www.fed-labs.com)

Leading contraband threat detection & field support, since 1937

AUTOCLEAR®  
[autoclearus.com](http://autoclearus.com)

Scintrex® • CheckGate® • Dynavision® • Control Screening® • Federal Labs®  
U.S. Canada Europe Dubai Latin America Beijing Hong Kong Singapore